

CLASSIC

Submittal

JV4/V4-AR14 20 24
Classic Architectural
Copper/Aluminum and
Steel Elements

Specification

JV4 Slip Jointed Enclosure

ENCLOSURE:

- STYLE: Classic
 OUTLET: Extruded Aluminum Pencil Proof
- LENGTHS: 2'0" thru 8'0" in 6" Increments
 MAT'L: 16 Ga. CRS (Std)
 14 Ga. CRS (Opt'l)
 16 Ga. Stainless Steel (Opt'l)*
 14 Ga. Stainless Steel (Opt'l)*
 14 Ga. Aluminum (Opt'l)
 12 Ga. Aluminum (Opt'l)
 *Available on "J" Style only
- HEIGHT: 14 7/16"
 20 7/16"
 24 7/16"
- FINISH: Baked Powder (Std)
 Baked Metallic (Opt'l)

ACCESSORIES:

- JV4 Overlapping Type
 V4 Underlapping Type
- All accessories return to the wall at the bottom and have pre-punched holes for fastening to the wall.

ELEMENT:

- TYPE: Cu/Al (Mechanically Expanded)
 LENGTHS: 2'0" thru 12'6" in 1" Increments for 1" & 1-1/4" Cu.
 2'0" thru 8'0" in 1" Increments for 3/4" Cu.
- One End Flared, (Std)
- TYPE: IPS Steel (Mechanically Expanded)
 LENGTHS: 2'0" Thru 12'0" in 1" Increments
 NPT Thread both Ends (Std)
 Beveled Ends for Field Weld
- See Catalog for Working Pressures

BRACKETS:

- Water Brkt w/B.B.
 Steam Brkt w/Brkt Mtd
 B.B. Hgr, Bracket Mtd
 B.B. Hgr, Wall Mtd
 Wall Mtd B.B. Hgr required for 3rd Tier Element

V4 Wiped Edge Enclosure

BACKPLATE:

- TYPE: Partial B/P
 LENGTHS: 8'0" Only
 MAT'L: 20 Ga. Prepainted (Std)
 18 Ga. Galvannealed (Opt'l)
- TYPE: Full Ht. B/P (Opt'l)
 LENGTHS: 2'0" thru 8'0" in 6" Increments
 MAT'L: 20 Ga. Galvannealed (Opt'l)
 20 Ga. Painted (Opt'l)
 18 Ga. Painted (Opt'l)
- AIRSEAL:** 1/8" x 3/8" Closed Cell (Opt'l)
- DAMPER:** Dial Type (Opt'l)
 Tamper Resistant (Opt'l)
 Slide Damper (Opt'l)

JV4/V4-AR14
(JV4 Shown)

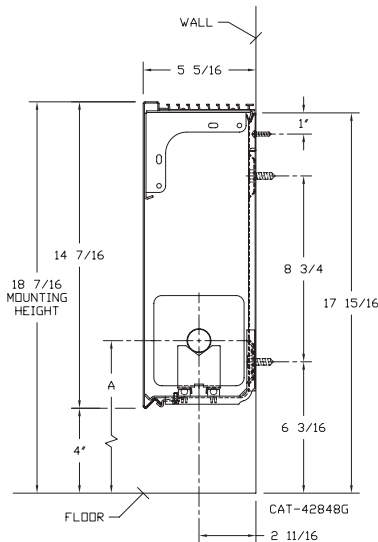

ELEMENT TUBE SIZE	FIN SIZE HEIGHT x WIDTH	CRADLE NUMBER	A
3/4 COPPER	3 5/8 x 4 1/4	2	7"
3/4 COPPER	4 1/4 x 4 1/4	3A	7 3/8"
1" COPPER	3 5/8 x 4 1/4	2	7 3/16"
1" COPPER	4 1/4 x 4 1/4	2	7 3/16"
1 1/4 COPPER	3 5/8 x 4 1/4	2	7 5/16"
1 1/4 COPPER	4 1/4 x 4 1/4	2	7 5/16"
1" STEEL	4 1/4 x 4 1/4	2	7 5/16"
1 1/4 STEEL	4 1/4 x 4 1/4	2	7 1/2"
2" STEEL	4 1/4 x 4 1/4	1	7 1/4"

JV4/V4-AR20 & 24
(JV4 Shown)

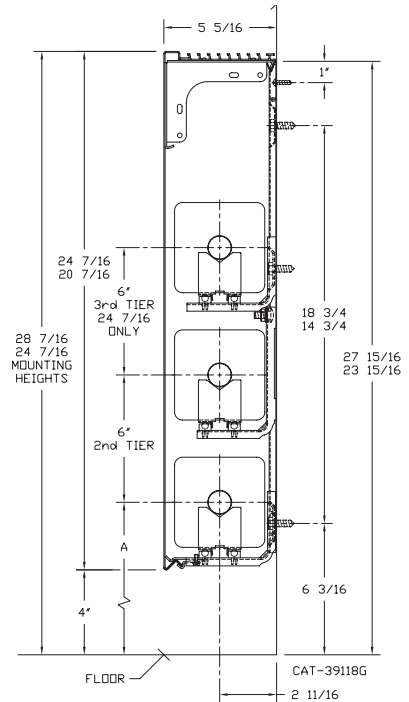

260 North Elm St., Westfield, MA 01085
 (413) 568-9571 Fax: (413) 564-5661
 www.vulcanrad.com



PROJECT: _____ DATE: _____
 LOCATION: _____
 ARCHITECT: _____
 ENGINEER: _____
 CONTRACTOR: _____
 PO NUMBER: _____

STYLE JV4/V4-AR14 20 24

COPPER/ALUMINUM ELEMENT RATINGS

ALL RATINGS ARE IN BTU/HR/LIN FT AND BASED ON 3 FPS VELOCITY, 65° EAT

TUBE SIZE	CATALOG DESIGNATION	FIN SIZE HEIGHT X WIDTH	FINS PER FT.	FIN THICKNESS IN INCHES	ENCL HEIGHT IN INCHES	TIERS AND CENTERS IN INCHES	MTG. HEIGHT IN INCHES	STEAM 215° FACTOR	HOT WATER (AVG.)								
									200°	190°	180°	170°	160°	150°	140°	130°	120°
									CORRECTION FACTORS FOR AVERAGE WATER TEMPERATURES								
1.00	0.86	0.78	0.69	0.61	0.53	0.45	.40	.33	.26								
3/4"	VC3/4-433	3-5/8" x 4-1/4"	32	.020	14	1	18-7/16	1360	1170	1060	940	830	720	610	540	450	350
					20	1	24-7/16	1400	1200	1090	970	850	740	630	560	460	360
					20	2-6 CL	24-7/16	2220	1910	1730	1530	1350	1180	1000	890	730	580
					24	1	28-7/16	1425	1230	1110	980	870	760	640	570	470	370
					24	2-6 CL	28-7/16	2270	1950	1770	1570	1380	1200	1020	910	750	590
3/4"	VC3/4-434	3-5/8" x 4-1/4"	40	.020	14	1	18-7/16	1620	1390	1260	1120	990	860	730	650	530	420
					20	1	24-7/16	1710	1470	1330	1180	1040	910	770	680	560	440
					20	2-6 CL	24-7/16	2390	2060	1860	1650	1460	1270	1080	960	790	620
					24	1	28-7/16	1800	1550	1400	1240	1100	950	810	720	590	470
					24	2-6 CL	28-7/16	2490	2140	1940	1720	1520	1320	1120	1000	820	650
3/4"	VC3/4-435	3-5/8" x 4-1/4"	50	.020	14	1	18-7/16	1780	1530	1390	1230	1090	940	800	710	590	460
					20	1	24-7/16	1940	1670	1510	1340	1180	1030	870	780	640	500
					20	2-6 CL	24-7/16	2400	2060	1870	1660	1460	1270	1080	960	790	620
					24	1	28-7/16	2080	1790	1620	1440	1270	1100	940	830	690	540
					24	2-6 CL	28-7/16	2530	2180	1970	1750	1540	1340	1140	1010	830	660
1"	VC433	3-5/8" x 4-1/4"	32	.020	14	1	18-7/16	1410	1210	1100	970	860	750	630	560	470	370
					20	1	24-7/16	1450	1250	1130	1000	880	770	650	580	480	380
					20	2-6 CL	24-7/16	2320	2000	1810	1600	1420	1230	1040	930	770	600
					24	1	28-7/16	1480	1270	1150	1020	900	780	670	590	490	380
					24	2-6 CL	28-7/16	2410	2070	1880	1660	1470	1280	1080	960	800	630
1"	VC434	3-5/8" x 4-1/4"	40	.020	14	1	18-7/16	1690	1450	1320	1170	1030	900	760	680	560	440
					20	1	24-7/16	1800	1550	1400	1240	1100	950	810	720	590	470
					20	2-6 CL	24-7/16	2510	2160	1960	1730	1530	1330	1130	1000	830	650
					24	1	28-7/16	1890	1630	1470	1300	1150	1000	850	760	620	490
					24	2-6 CL	28-7/16	2660	2290	2070	1840	1620	1410	1200	1060	880	690
1"	VC435	3-5/8" x 4-1/4"	50	.020	14	1	18-7/16	1850	1590	1440	1280	1130	980	830	740	610	480
					20	1	24-7/16	2030	1750	1580	1400	1240	1080	910	810	670	530
					20	2-6 CL	24-7/16	2510	2160	1960	1730	1530	1330	1130	1000	830	650
					24	1	28-7/16	2170	1870	1690	1500	1320	1150	980	870	720	560
					24	2-6 CL	28-7/16	2660	2290	2070	1840	1620	1410	1200	1060	880	690
1-1/4"	VC1433	3-5/8" x 4-1/4"	32	.020	14	1	18-7/16	1380	1190	1080	950	840	730	620	550	460	360
					20	1	24-7/16	1420	1220	1110	980	870	750	640	570	470	370
					20	2 @ 6 CL	24-7/16	2280	1960	1780	1570	1390	1210	1030	910	750	590
					24	1	28-7/16	1450	1250	1130	1000	880	770	650	580	480	380
					24	2 @ 6 CL	28-7/16	2370	2040	1850	1640	1450	1260	1070	950	780	620
1-1/4"	VC1434	3-5/8" x 4-1/4"	40	.020	14	1	18-7/16	1660	1430	1290	1150	1010	880	750	660	550	430
					20	1	24-7/16	1760	1510	1370	1210	1070	930	790	700	580	460
					20	2 @ 6 CL	24-7/16	2460	2120	1920	1700	1500	1300	1110	980	810	640
					24	1	28-7/16	1850	1590	1440	1280	1130	980	830	740	610	480
					24	2 @ 6 CL	28-7/16	2600	2240	2030	1790	1590	1380	1170	1040	860	680
1-1/4"	VC1435	3-5/8" x 4-1/4"	50	.020	14	1	18-7/16	1760	1510	1370	1210	1070	930	790	700	580	460
					20	1	24-7/16	1920	1650	1500	1320	1170	1020	860	770	630	500
					20	2 @ 6 CL	24-7/16	2370	2040	1850	1640	1450	1260	1070	950	780	620
					24	1	28-7/16	2050	1760	1600	1410	1250	1090	920	820	680	530
					24	2 @ 6 CL	28-7/16	2500	2150	1950	1720	1530	1330	1130	1000	830	650
3/4"	VC3/4-43	4-1/4" SQ.	32	.020	14	1	18-7/16	1470	1260	1150	1010	900	780	660	590	490	380
					20	1	24-7/16	1540	1320	1200	1060	940	820	690	620	510	400
					20	2-6 CL	24-7/16	2310	1990	1800	1590	1410	1220	1040	920	760	600
					24	1	28-7/16	1570	1350	1220	1080	960	830	710	630	520	410
					24	2-6 CL	28-7/16	2410	2070	1880	1660	1470	1280	1080	960	800	630
24	3-6 CL	28-7/16	2770	2380	2160	1910	1690	1470	1250	1110	910	720					

STYLE JV4/V4-AR14 20 24

COPPER/ALUMINUM ELEMENT RATINGS

ALL RATINGS ARE IN BTU/HR/LIN FT AND BASED ON 3 FPS VELOCITY, 65° EAT

TUBE SIZE	CATALOG DESIGNATION	FIN SIZE HEIGHT X WIDTH	FINS PER FT.	FIN THICKNESS IN INCHES	ENCL HEIGHT IN INCHES	TIERS AND CENTERS IN INCHES	MTG. HEIGHT IN INCHES	STEAM 215° FACTOR	HOT WATER (AVG.)									
									200°	190°	180°	170°	160°	150°	140°	130°	120°	
									CORRECTION FACTORS FOR AVERAGE WATER TEMPERATURES									
									1.00	0.86	0.78	0.69	0.61	0.53	0.45	.40	.33	.26
3/4"	VC3/4-44	4-1/4" SQ.	40	.020	14	1	18-7/16	1840	1580	1440	1270	1120	980	830	740	610	480	
					20	1	24-7/16	1950	1680	1520	1350	1190	1030	880	780	640	510	
					20	2-6 CL	24-7/16	2360	2030	1840	1630	1440	1250	1060	940	780	610	
					24	1	28-7/16	2070	1780	1610	1430	1260	1100	930	830	680	540	
					24	2-6 CL	28-7/16	2550	2190	1990	1760	1560	1350	1150	1020	840	660	
3/4"	VC3/4-45	4-1/4" SQ.	50	.020	14	1	18-7/16	1870	1610	1460	1290	1140	990	840	750	620	490	
					20	1	24-7/16	2050	1760	1600	1410	1250	1090	920	820	680	530	
					20	2-6 CL	24-7/16	2480	2130	1930	1710	1510	1310	1120	990	820	640	
					24	1	28-7/16	2200	1890	1720	1520	1340	1170	990	880	730	570	
					24	2-6 CL	28-7/16	2670	2300	2080	1840	1630	1420	1200	1070	880	690	
1"	VC43	4-1/4" SQ.	32	.020	14	1	18-7/16	1470	1260	1150	1010	900	780	660	590	490	380	
					20	1	24-7/16	1540	1320	1200	1060	940	820	690	620	510	400	
					20	2-6 CL	24-7/16	2340	2010	1830	1610	1430	1240	1050	940	770	610	
					24	1	28-7/16	1580	1360	1230	1090	960	840	710	630	520	410	
					24	2-6 CL	28-7/16	2440	2100	1900	1680	1490	1290	1100	980	810	630	
1"	VC44	4-1/4" SQ.	40	.020	14	1	18-7/16	1720	1480	1340	1190	1050	910	770	690	570	450	
					20	1	24-7/16	1810	1560	1410	1250	1100	960	810	720	600	470	
					20	2-6 CL	24-7/16	2510	2160	1960	1730	1530	1330	1130	1000	830	650	
					24	1	28-7/16	1920	1650	1500	1320	1170	1020	860	770	630	500	
					24	2-6 CL	28-7/16	2600	2240	2030	1790	1590	1380	1170	1040	860	680	
1"	VC45	4-1/4" SQ.	50	.020	14	1	18-7/16	1900	1630	1480	1310	1160	1010	860	760	630	490	
					20	1	24-7/16	2090	1800	1630	1440	1270	1110	940	840	690	540	
					20	2-6 CL	24-7/16	2510	2160	1960	1730	1530	1330	1130	1000	830	650	
					24	1	28-7/16	2250	1940	1760	1550	1370	1190	1010	900	740	590	
					24	2-6 CL	28-7/16	2710	2330	2110	1870	1650	1440	1220	1080	890	700	
1-1/4"	VC143	4-1/4" SQ.	32	.020	14	1	18-7/16	1440	1240	1120	990	880	760	650	580	480	370	
					20	1	24-7/16	1510	1300	1180	1040	920	800	680	600	500	390	
					20	2-6 CL	24-7/16	2300	1980	1790	1590	1400	1220	1040	920	760	600	
					24	1	28-7/16	1550	1330	1210	1070	950	820	700	620	510	400	
					24	2-6 CL	28-7/16	2390	2060	1860	1650	1460	1270	1080	960	790	620	
1-1/4"	VC144	4-1/4" SQ.	40	.020	14	1	18-7/16	1690	1450	1320	1170	1030	900	760	680	560	440	
					20	1	24-7/16	1780	1530	1390	1230	1090	940	800	710	590	460	
					20	2-6 CL	24-7/16	2460	2120	1920	1700	1500	1300	1110	980	810	640	
					24	1	28-7/16	1890	1630	1470	1300	1150	1000	850	760	620	490	
					24	2-6 CL	28-7/16	2550	2190	1990	1760	1560	1350	1150	1020	840	660	
1-1/4"	VC145	4-1/4" SQ.	50	.020	14	1	18-7/16	1870	1610	1460	1290	1140	990	840	750	620	490	
					20	1	24-7/16	2050	1760	1600	1410	1250	1090	920	820	680	530	
					20	2-6 CL	24-7/16	2460	2120	1920	1700	1500	1300	1110	980	810	640	
					24	1	28-7/16	2210	1900	1720	1520	1350	1170	990	880	730	570	
					24	2-6 CL	28-7/16	2650	2280	2070	1830	1620	1400	1190	1060	870	690	
1-1/4"	VC145	4-1/4" SQ.	50	.020	14	1	18-7/16	1870	1610	1460	1290	1140	990	840	750	620	490	
					20	1	24-7/16	2050	1760	1600	1410	1250	1090	920	820	680	530	
					20	2-6 CL	24-7/16	2460	2120	1920	1700	1500	1300	1110	980	810	640	
					24	1	28-7/16	2210	1900	1720	1520	1350	1170	990	880	730	570	
					24	2-6 CL	28-7/16	2650	2280	2070	1830	1620	1400	1190	1060	870	690	
1-1/4"	VC145	4-1/4" SQ.	50	.020	14	1	18-7/16	1870	1610	1460	1290	1140	990	840	750	620	490	
					20	1	24-7/16	2050	1760	1600	1410	1250	1090	920	820	680	530	
					20	2-6 CL	24-7/16	2460	2120	1920	1700	1500	1300	1110	980	810	640	
					24	1	28-7/16	2210	1900	1720	1520	1350	1170	990	880	730	570	
					24	2-6 CL	28-7/16	2650	2280	2070	1830	1620	1400	1190	1060	870	690	
1-1/4"	VC145	4-1/4" SQ.	50	.020	14	1	18-7/16	1870	1610	1460	1290	1140	990	840	750	620	490	
					20	1	24-7/16	2050	1760	1600	1410	1250	1090	920	820	680	530	
					20	2-6 CL	24-7/16	2460	2120	1920	1700	1500	1300	1110	980	810	640	
					24	1	28-7/16	2210	1900	1720	1520	1350	1170	990	880	730	570	
					24	2-6 CL	28-7/16	2650	2280	2070	1830	1620	1400	1190	1060	870	690	
1-1/4"	VC145	4-1/4" SQ.	50	.020	14	1	18-7/16	1870	1610	1460	1290	1140	990	840	750	620	490	
					20	1	24-7/16	2050	1760	1600	1410	1250	1090	920	820	680	530	
					20	2-6 CL	24-7/16	2460	2120	1920	1700	1500	1300	1110	980	810	640	
					24	1	28-7/16	2210	1900	1720	1520	1350	1170	990	880	730	570	
					24	2-6 CL	28-7/16	2650	2280	2070	1830	1620	1400	1190	1060	870	690	

STYLE JV4/V4-AR14, 20 & 24

STEEL ELEMENT RATINGS

ALL RATINGS ARE IN BTU/HR/LIN FT AND BASED ON 3 FPS VELOCITY, 65° EAT

TUBE SIZE	CATALOG DESIGNATION	FIN SIZE HEIGHT X WIDTH	FINS PER FT.	FIN THICKNESS IN INCHES	ENCL HEIGHT IN INCHES	TIERS AND CENTERS IN INCHES	MTG. HEIGHT IN INCHES	STEAM 215° FACTOR	HOT WATER (AVG.)								
									200°	190°	180°	170°	160°	150°	140°	130°	120°
									CORRECTION FACTORS FOR AVERAGE WATER TEMPERATURES								
								1.00	0.86	0.78	0.69	0.61	0.53	0.45	.40	.33	.26
1"	VS43	4-1/4" SQ.	32	.032	14	1	18-7/16	1210	1040	940	830	740	640	540	480	400	310
					20	1	24-7/16	1270	1090	990	880	770	670	570	510	420	330
					20	2-6 CL	24-7/16	2080	1790	1620	1440	1270	1100	940	830	690	540
					24	1	28-7/16	1310	1130	1020	900	800	690	590	520	430	340
					24	2-6 CL	28-7/16	2120	1820	1650	1460	1290	1120	950	850	700	550
1"	VS44	4-1/4" SQ.	40	.032	14	1	18-7/16	1440	1240	1120	990	880	760	650	580	480	370
					20	1	24-7/16	1530	1320	1190	1060	930	810	690	610	500	400
					20	2-6 CL	24-7/16	2330	2000	1820	1610	1420	1230	1050	930	770	610
					24	1	28-7/16	1600	1380	1250	1100	980	850	720	640	530	420
					24	2-6 CL	28-7/16	2395	2060	1870	1650	1460	1270	1080	960	790	620
1"	VS45	4-1/4" SQ.	50	.032	14	1	18-7/16	1490	1280	1160	1030	910	790	670	600	490	390
					20	1	24-7/16	1565	1350	1220	1080	950	830	700	630	520	410
					20	2-6 CL	24-7/16	2285	1970	1780	1580	1390	1210	1030	910	750	590
					24	1	28-7/16	1620	1390	1260	1120	990	860	730	650	530	420
					24	2-6 CL	28-7/16	2320	2000	1810	1600	1420	1230	1040	930	770	600
1-1/4"	VS143	4-1/4" SQ.	32	.032	14	1	18-7/16	1110	950	870	770	680	590	500	440	370	290
					20	1	24-7/16	1170	1010	910	810	710	620	530	470	390	300
					20	2-6 CL	24-7/16	1910	1640	1490	1320	1170	1010	860	760	630	500
					24	1	28-7/16	1200	1030	940	830	730	640	540	480	400	310
					24	2-6 CL	28-7/16	1940	1670	1510	1340	1180	1030	870	780	640	500
1-1/4"	VS144	4-1/4" SQ.	40	.032	14	1	18-7/16	1430	1230	1120	990	870	760	640	570	470	370
					20	1	24-7/16	1520	1310	1190	1050	930	810	680	610	500	400
					20	2-6 CL	24-7/16	2240	1930	1750	1550	1370	1190	1010	900	740	580
					24	1	28-7/16	1590	1370	1240	1100	970	840	720	640	520	410
					24	2-6 CL	28-7/16	2300	1980	1790	1590	1400	1220	1040	920	760	600
1-1/4"	VS145	4-1/4" SQ.	50	.032	14	1	18-7/16	1460	1260	1140	1010	890	770	660	580	480	380
					20	1	24-7/16	1535	1320	1200	1060	940	810	690	610	510	400
					20	2-6 CL	24-7/16	2240	1930	1750	1550	1370	1190	1010	900	740	580
					24	1	28-7/16	1595	1370	1240	1100	970	850	720	640	530	410
					24	2-6 CL	28-7/16	2275	1960	1770	1570	1390	1210	1020	910	750	590
2"	VS242	4-1/4" SQ.	25	.032	14	1	18-7/16	1090	940	850	750	660	580	490	440	360	280
					20	1	24-7/16	1130	970	880	780	690	600	510	450	370	290
					20	2-6 CL	24-7/16	1830	1570	1430	1260	1120	970	820	730	600	480
					24	1	28-7/16	1150	990	900	790	700	610	520	460	380	300
					24	2-6 CL	28-7/16	1850	1590	1440	1280	1130	980	830	740	610	480
2"	VS243	4-1/4" SQ.	32	.032	14	1	18-7/16	1290	1110	1010	890	790	680	580	520	430	340
					20	1	24-7/16	1330	1140	1040	920	810	700	600	530	440	350
					20	2-6 CL	24-7/16	2030	1750	1580	1400	1240	1080	910	810	670	530
					24	1	28-7/16	1380	1190	1080	950	840	730	620	550	460	360
					24	2-6 CL	28-7/16	2060	1770	1610	1420	1260	1090	930	820	680	540
24	3-6 CL	28-7/16	2370	2040	1850	1640	1450	1260	1070	950	780	620					

ELEMENT CENTERLINE DIMENSIONS FOR INSTALLATIONS USING STEAM

STEAM BRACKET W/ BRACKET MOUNTED HANGER

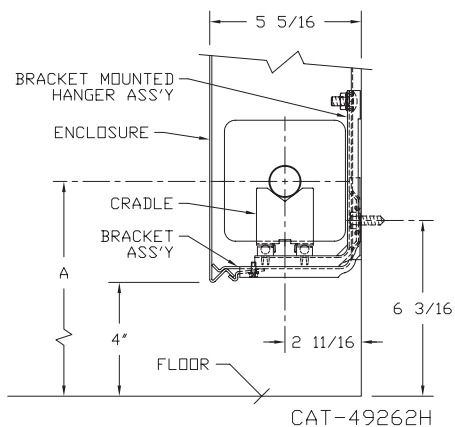

ELEMENT TUBE SIZE	FIN SIZE HEIGHT X WIDTH	CRADLE NUMBER	A MIN	A MAX
3/4 COPPER	3 5/8 x 4 1/4	2	7 3/8	8 3/4
	4 1/4 x 4 1/4	3A	7 11/16	9 1/16
1" COPPER	3 5/8 x 4 1/4	2	7 1/2	8 7/8
	4 1/4 x 4 1/4			
1 1/4 COPPER	3 5/8 x 4 1/4	2	7 5/8	9"
	4 1/4 x 4 1/4			
1" STEEL	4 1/4 x 4 1/4	2	7 5/8	9"
1 1/4 STEEL	4 1/4 x 4 1/4	2	7 7/8	9 1/4
2" STEEL	4 1/4 x 4 1/4	1	7 5/8	9"

WALL MOUNTED BRACKET/LOUVERED INLET RETURN TO WALL

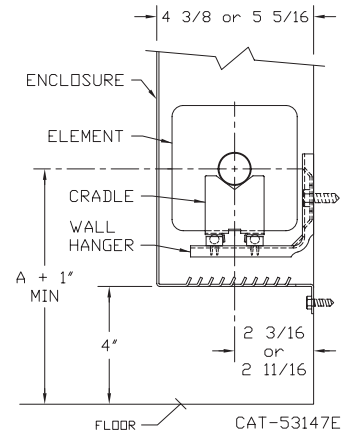

DESIGN DATA

COMMERCIAL FINNED TUBE RATING CORRECTION CHARTS

CATALOG FINNED TUBE RATINGS ARE BASED UPON THE FOLLOWING CONDITIONS:

- 215°F AVERAGE WATER OR STEAM TEMPERATURE
- 65°F ENTERING AIR TEMPERATURE
- 3 FEET PER SECOND WATER FLOW RATE
- CATALOG MOUNTING HEIGHT

USE THE FOLLOWING CALCULATION WITH CORRECTION FACTORS FOR JOB CONDITIONS TO DETERMINE CORRECTED RATING:

$$\text{CORRECTED RATING} = (\text{215°F CATALOG RATING}) \times \left(\frac{\text{CORRECTION FACTOR FOR STEAM OR WATER AND AVERAGE AIR TEMP.}}{\text{CORRECTION FACTOR FOR FLOW RATE}} \right) \times \left(\frac{\text{CORRECTION FOR MOUNTING HTG.-SEE CATALOG RATING}}{\text{CORRECTION FACTOR FOR MOUNTING HTG.-SEE CATALOG RATING}} \right)$$

USE THE FOLLOWING CHARTS TO SELECT CORRECTION FACTORS

CHART/WATER VEL./CORR. FACTOR / PRESS. DROP/TOTAL BTU.

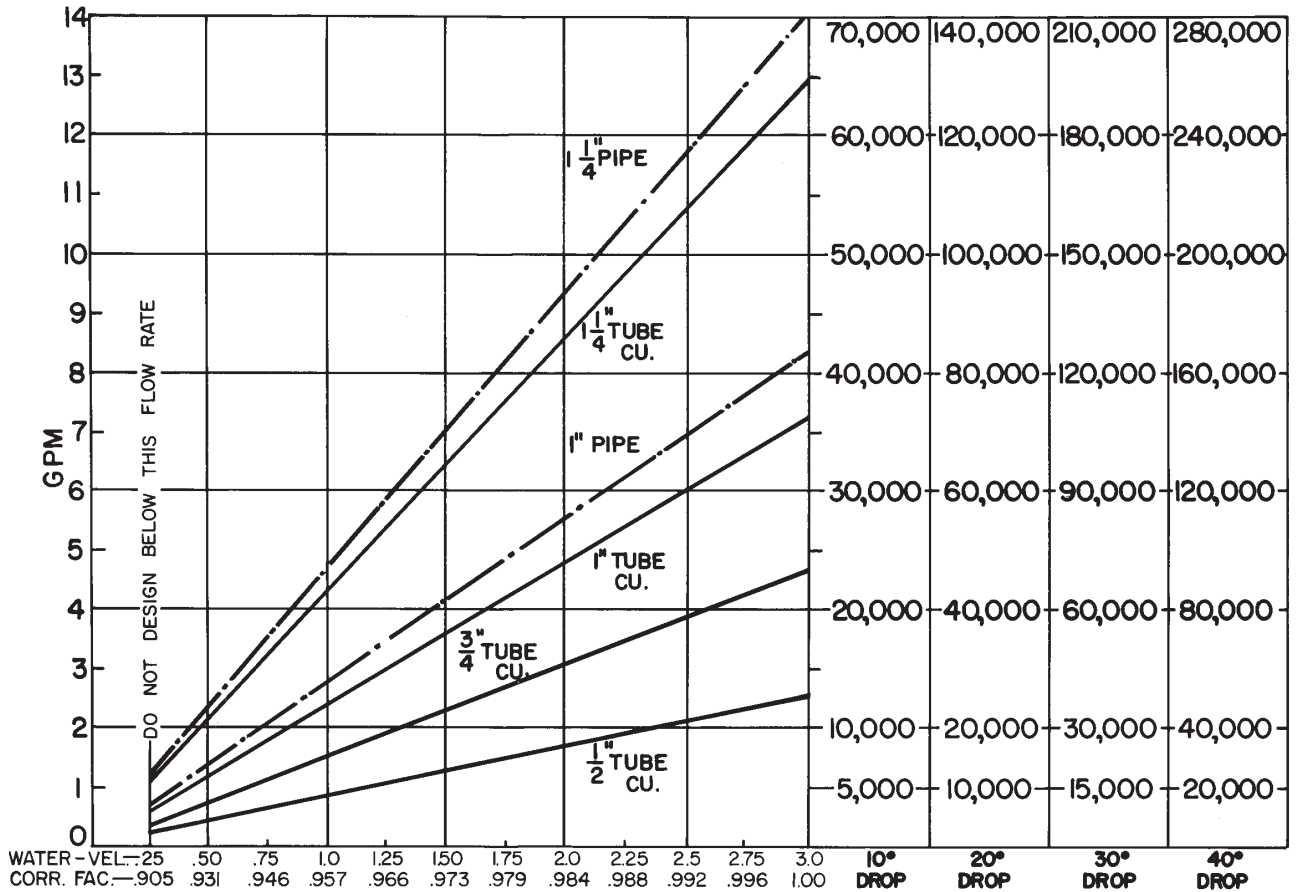

1/2" COP. ALUM.	1,80	2,33	5,33	9,16												
3/4" COP. ALUM.	.5	1,5	3,16	5,4	6,25											
1" COP. ALUM.	.233	.41	.83	1,45	2,16	2,83	3,66									
1" PIPE	.37	.79	1,3	2,00	2,70	3,70	4,80									
1 1/4" COP. ALUM.	.16	.33	.55	.79	1,08	1,33	1,8	2,25	2,26	2,91	3,3					
1 1/4" PIPE	.09	.18	.31	.5	.70	1,0	1,1	1,3	1,6	1,8	2,58	2,3	3,3			

PRESSURE DROP PER 100 LINEAR FT., IN FEET OF HEAD

DESIGN DATA

INLET AIR CORRECTION FACTOR

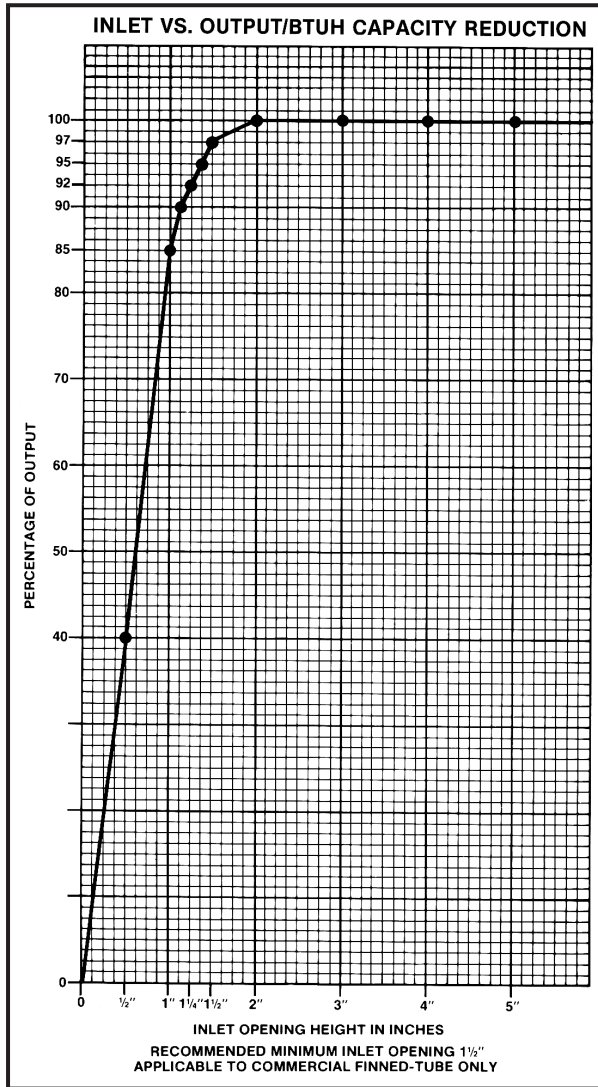

GUARANTEED WORKING PRESSURES

- 1" IPS — 780 AT TEMPERATURES UP TO 650°F.
 - 1 1/4" IPS — 660 AT TEMPERATURES UP TO 650°F.
 - 2" IPS — 405 AT TEMPERATURES UP TO 650°F.
 - 1 1/4" CU — 194 AT TEMPERATURES UP TO 300°F.
 - 1" CU — 204 AT TEMPERATURES UP TO 300°F.
 - 3/4" CU — 218 PSI AT TEMPERATURES UP TO 300°F.
- MAXIMUM PRESSURES AT OTHER TEMPERATURES ARE AVAILABLE UPON REQUEST.

RATE OF PITCH FOR STEAM 1/2" DROP OVER 20 FT. RUN.

PIPE WATER CAPACITIES AND QUANTITIES CIRCULATED AT VELOCITY OF 3* FEET PER SECOND			
Pipe Size	Gals. Per Linear Ft.	Gals./Min. @ 3' Sec. Vel.*	Lbs./Hr. @ 3' Sec. Vel.*
1/2"	.016	2.88	1440
3/4"	.023	4.14	2070
1"	.040	7.20	3600
1 1/4"	.063	11.34	5660
1 1/2"	.102	18.36	9160
2"	.170	30.60	15300
2 1/2"	.275	49.50	24850
3"	.390	70.20	35000

*3 Ft./Sec. Velocity is Basic for Hot Water Rating Factors Shown on this Page.

$$\text{VELOCITY FT./SEC.} = \frac{\text{LBS. PER HOUR}}{(\text{GALS. PER FT.}) (3600) (8.3)}$$

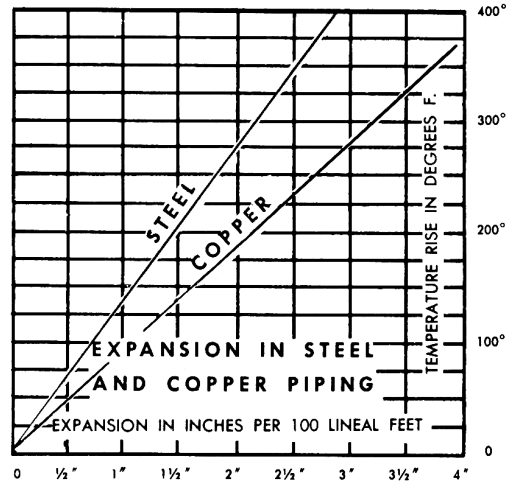

GLYCOL CORRECTION FACTORS

Fluid Temperature 200°F

% Solution	Ethylene Glycol	Propylene Glycol
20	.952	.988
30	.921	.968
40	.888	.943
50	.852	.912

Fluid Temperature 180°F

% Solution	Ethylene Glycol	Propylene Glycol
20	.946	.982
30	.913	.961
40	.879	.934
50	.842	.902

Fluid Temperature 140°F

% Solution	Ethylene Glycol	Propylene Glycol
20	.934	.97
30	.898	.946
40	.861	.916
50	.821	.881

ALTITUDE FACTORS

Approximate factors for convective heat value at varying altitudes

Altitude	Ferrous Units	Copper Alum. Units
Sea Level	1.000	1.000
1,000 ft.	.984	.969
2,000 ft.	.968	.938
3,000 ft.	.952	.908
4,000 ft.	.936	.878
5,000 ft.	.920	.850
6,000 ft.	.904	.822
7,000 ft.	.889	.795
8,000 ft.	.874	.768
9,000 ft.	.859	.743
10,000 ft.	.844	.718
15,000 ft.	.771	.603
20,000 ft.	.703	.502

CORRECTION FACTORS FOR STEAM PRESSURES AND AIR TEMPERATURES OTHER THAN STANDARD

STEAM		ENTERING AIR TEMPERATURE, °F														
Pressure		Temp.			STD											
Gauge	Abs. Psi	°F	45	55	65	70	75	80	85	90	100	110	120	130	140	150
(Vac) 15" Hg	7.32	178.9	0.90	0.80	0.70	0.65	0.60	0.56	0.51	0.45	0.39	0.32	0.25	0.18	0.13	0.08
(Vac) 10"	9.78	192.2	1.02	0.91	0.81	0.76	0.71	0.66	0.62	0.55	0.48	0.40	0.33	0.26	0.20	0.14
(Vac) 5"	12.25	202.9	1.11	1.00	0.90	0.85	0.79	0.75	0.70	0.63	0.56	0.48	0.40	0.33	0.27	0.20
(Vac) 0 Psi	14.696	212.0	1.19	1.09	0.97	0.92	0.87	0.82	0.77	0.70	0.63	0.54	0.46	0.38	0.31	0.25
▶ .899	15.595	215.0	1.22	1.11	1.00	0.95	0.90	0.84	0.80	0.75	0.65	0.57	0.48	0.40	0.33	0.26
5	19.70	227.1	1.34	1.22	1.11	1.05	1.00	0.95	0.90	0.81	0.75	0.66	0.57	0.49	0.41	0.34
10	24.70	239.4	1.45	1.33	1.22	1.17	1.11	1.05	1.00	0.91	0.85	0.75	0.66	0.58	0.50	0.42
15	29.70	249.8	1.55	1.43	1.31	1.26	1.20	1.14	1.09	1.00	0.94	0.84	0.75	0.66	0.57	0.49
20	34.70	258.8	1.63	1.52	1.40	1.33	1.28	1.23	1.17	1.07	1.02	0.92	0.82	0.73	0.64	0.55
25	39.70	266.8	1.71	1.59	1.47	1.41	1.36	1.30	1.25	1.15	1.09	0.98	0.89	0.80	0.71	0.62
30	44.70	274.0	1.78	1.66	1.54	1.48	1.42	1.37	1.31	1.21	1.15	1.05	0.95	0.85	0.76	0.68
40	54.70	286.7	1.91	1.79	1.66	1.61	1.54	1.49	1.43	1.32	1.27	1.16	1.06	0.97	0.87	0.78
50	64.70	297.7	2.02	1.90	1.77	1.71	1.65	1.60	1.54	1.42	1.37	1.26	1.16	1.06	0.96	0.87
60	74.70	307.3	2.10	2.00	1.87	1.81	1.75	1.69	1.63	1.51	1.47	1.35	1.25	1.15	1.05	0.95
70	84.70	316.0	2.20	2.09	1.95	1.89	1.83	1.77	1.71	1.59	1.55	1.44	1.33	1.23	1.12	1.03
80	94.70	323.9	2.27	2.17	2.03	1.97	1.91	1.85	1.80	1.69	1.63	1.52	1.41	1.31	1.20	1.10
90	104.70	331.2	2.36	2.24	2.11	2.05	1.98	1.93	1.87	1.74	1.70	1.59	1.48	1.38	1.28	1.17
100	114.70	337.9	2.43	2.31	2.18	2.11	2.05	2.00	1.94	1.81	1.77	1.65	1.54	1.44	1.33	1.23
125	139.70	352.9	2.59	2.47	2.33	2.27	2.21	2.16	2.10	1.96	1.92	1.80	1.69	1.59	1.48	1.38
150	164.70	365.9	2.73	2.62	2.47	2.43	2.35	2.29	2.23	2.08	2.05	1.94	1.82	1.72	1.61	1.51
175	189.70	377.4	2.86	2.74	2.60	2.54	2.47	2.41	2.35	2.21	2.17	2.05	1.95	1.85	1.73	1.63
200	214.70	387.8	2.95	2.85	2.71	2.63	2.58	2.52	2.47	2.31	2.29	2.17	2.06	1.96	1.84	1.75

From Keenan and Keyes — Linear Interpolation.

Note: Gauge pressure should be corrected for altitude.

CORRECTION FACTORS FOR WATER TEMPERATURES AND AIR TEMPERATURES OTHER THAN STANDARD

AVERAGE WATER TEMP. °F	ENTERING AIR TEMPERATURE, °F														
	45	55	STD	70	75	80	85	90	95	100	110	120	130	140	150
90	.19	.13	.11	.06											
100	.25	.19	.15	.11	.08	.06									
110	.31	.25	.20	.16	.13	.11	.08	.06							
120	.38	.31	.26	.21	.19	.16	.13	.11	.08	.06					
130	.45	.38	.33	.28	.25	.21	.19	.16	.13	.11	.06				
140	.53	.45	.40	.34	.31	.28	.25	.21	.19	.16	.11	.06			
150	.61	.53	.45	.41	.38	.34	.31	.28	.25	.21	.16	.11	.06		
160	.69	.61	.53	.49	.45	.41	.38	.34	.31	.28	.21	.16	.11	.06	
170	.77	.69	.61	.57	.53	.49	.45	.41	.38	.34	.28	.21	.16	.11	.06
180	.86	.77	.69	.65	.61	.57	.53	.49	.45	.41	.34	.28	.21	.16	.11
190	.95	.86	.78	.73	.69	.65	.61	.57	.53	.49	.41	.34	.28	.21	.16
200	1.05	.95	.86	.82	.77	.73	.69	.65	.61	.57	.49	.41	.34	.28	.21
210	1.14	1.05	.95	.91	.86	.82	.77	.73	.69	.65	.57	.49	.41	.34	.28
▶ 215 (STD.)	1.19	1.09	1.00	.95	.91	.86	.82	.77	.73	.69	.61	.53	.45	.38	.31
220	1.24	1.14	1.05	1.00	.95	.91	.86	.82	.77	.73	.65	.57	.49	.41	.34
230	1.34	1.24	1.14	1.09	1.05	1.00	.95	.91	.86	.82	.73	.65	.57	.49	.41
240	1.44	1.34	1.25	1.19	1.14	1.09	1.05	1.00	.95	.91	.82	.73	.65	.57	.49
250	1.55	1.44	1.34	1.29	1.24	1.19	1.14	1.09	1.05	1.00	.91	.82	.73	.65	.57
260	1.66	1.55	1.44	1.39	1.34	1.29	1.24	1.19	1.14	1.09	1.00	.91	.82	.73	.65
270	1.76	1.66	1.55	1.50	1.44	1.39	1.34	1.29	1.24	1.19	1.09	1.00	.91	.82	.73
280	1.87	1.76	1.66	1.60	1.55	1.50	1.44	1.39	1.34	1.29	1.19	1.09	1.00	.91	.82
290	1.99	1.87	1.76	1.71	1.66	1.60	1.55	1.50	1.44	1.39	1.29	1.19	1.09	1.00	.91
300	2.10	1.99	1.87	1.82	1.76	1.71	1.66	1.60	1.55	1.50	1.39	1.29	1.19	1.09	1.00